



GET STARTED



LOADING #1



Toegang tot Get Started online

Voor de audio- en andere bestanden log je in op app.schoolsupport.nl via Basispoort, toegangonderwijs.nl of Entree.



GET STARTED #1

Auteur	Ron Riemens
Eindredactie	Schoolsupport
Vormgeving	Ron Riemens & Peggy Van Eyck
Omslagontwerp	Marino Pollet
Illustraties	© Hemera

© Uitgeverij Schoolsupport
E: service@schoolsupport.nl
www.schoolsupport.nl/getstarted

© Schoolsupport bv. Alle rechten voorbehouden. Niets uit deze uitgave mag worden verveelvoudigd, opgeslagen in een geautomatiseerd gegevensbestand, of openbaar gemaakt in enige vorm of op enige wijze, hetzij elektronisch, mechanisch, of door fotokopiëren, zonder voorafgaande schriftelijke toestemming van de uitgever.
De uitgever heeft getracht de rechthebbenden van het illustratiemateriaal te achterhalen. Indien iemand meent dat rechten niet zijn gehonoreerd, dan kan hij of zij zich wenden tot de uitgever.



A mouse, B crocodile, C goat, D rhino

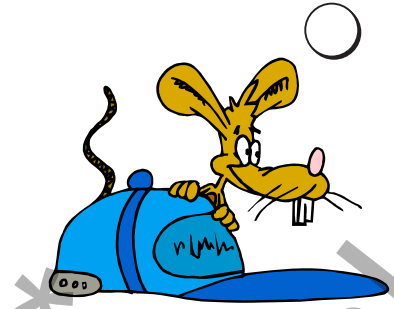
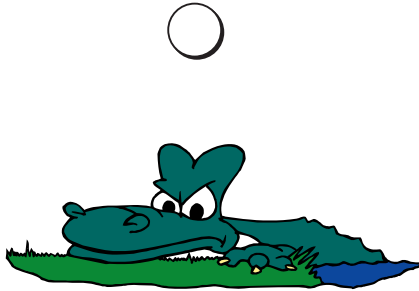

Match the words with their descriptions.

- | | | |
|------------|----------------------------|---|
| 1 camel | <input type="checkbox"/> S | A a small animal with black fur that lives underground |
| 2 mole | <input type="checkbox"/> | M this animal uses its teeth to cut wood and build dams in rivers |
| 3 bat | <input type="checkbox"/> | N a small brown animal with sharp spikes on its back |
| 4 beaver | <input type="checkbox"/> | O an African wild animal with black and white stripes |
| 5 zebra | <input type="checkbox"/> | S an animal with a long neck and two lumps on its back |
| 6 hedgehog | <input type="checkbox"/> | L a small flying animal that looks like a mouse with wings made of skin |

Underline the words that rhyme.

I'm a mole
and dig around
I live my life
under the ground
I can't see very well, it's true
but I can smell and hear
much better than you!
(na-na-na-na-na ...)

Can you read the names of these five animals?

- | | | | |
|---|--------------------------------------|---|----------------------|
| 1 | <input type="text" value="snrgs"/> | → | <input type="text"/> |
| 2 | <input type="text" value="sewse"/> | → | <input type="text"/> |
| 3 | <input type="text" value="elru"/> | → | <input type="text"/> |
| 4 | <input type="text" value="rseter"/> | → | <input type="text"/> |
| 5 | <input type="text" value="trnqele"/> | → | <input type="text"/> |

Write the words in alphabetical order.

lion, dolphin, llama, spider, deer, donkey

1	<input type="text"/>	<input type="text"/>	<input type="text"/>	<input type="text"/>	<input type="text"/>	1	<input type="text"/>
2	<input type="text"/>	<input type="text"/>	<input type="text"/>	<input type="text"/>	<input type="text"/>	2	<input type="text"/>
3	<input type="text"/>	<input type="text"/>	<input type="text"/>	<input type="text"/>	<input type="text"/>	3	<input type="text"/>
4	<input type="text"/>	<input type="text"/>	<input type="text"/>	<input type="text"/>	<input type="text"/>	4	<input type="text"/>
5	<input type="text"/>	<input type="text"/>	<input type="text"/>	<input type="text"/>	<input type="text"/>	5	<input type="text"/>
6	<input type="text"/>	<input type="text"/>	<input type="text"/>	<input type="text"/>	<input type="text"/>	6	<input type="text"/>

Write the correct letters in the circles.

A nose, B basket, C whisker, D feet, E ear

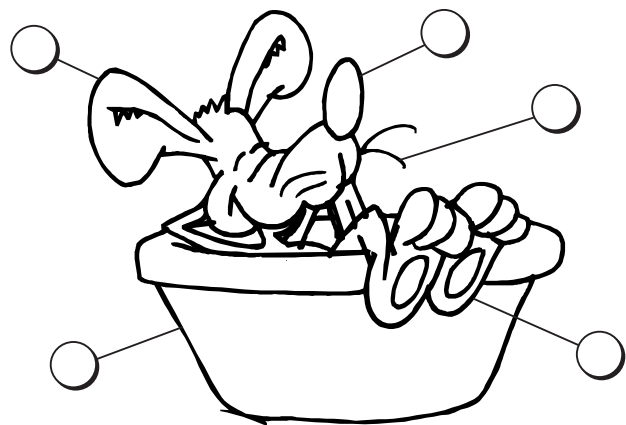



Practise this dialogue with a classmate.

I feel like crying. Tiger has gone missing.

Tell me, when did you last see your cat?

On Monday. Almost three days ago.

I'm sure he will come back! They always do.

But he never stays away for so long.

Something is scratching at the door.

I miss him so much. He must be dead.

Don't be silly. I'm going to have a look.

Ran over by a car, or hit by lightning.

Well, well. Who have we got here? Alive!

Tiger, my sweetie. Yuck! What's that?

It looks like a mouse to me. A dead one.

What have you done? Get out of here!

But didn't you want him back?

Ask a classmate the following questions.

- 1 Do you have a pet animal?
- 2 If you don't, would you like to have one?
- 3 Are there many cats in your neighbourhood?
- 4 Have you ever stepped in dog poop?
- 5 Some people are afraid of dogs. Are you?
- 6 What would you do when your pet was missing?
- 7 Can you imitate the sound of a cat (meow)?
- 8 Which animal would you like to be yourself?

Useful words and phrases.

- pet animal huisdier
- ran over overreden
- lightning bliksem
- don't be silly doe niet zo gek
- neighbourhood buurt

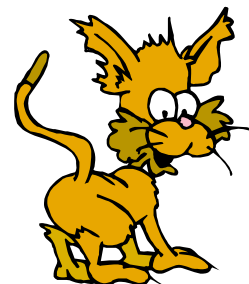

Write these seven words in alphabetical order.

airplane, almost, accident, always, adventure, awake, activity

1	ongeluk	<input type="text"/>	<input type="text"/>	<input type="text"/>	<input type="text"/>	<input type="text"/>	<input type="text"/>	<input type="text"/>	<input type="text"/>	<input type="text"/>	<input type="text"/>	1	<input type="text"/>
2	activiteit	<input type="text"/>	<input type="text"/>	<input type="text"/>	<input type="text"/>	<input type="text"/>	<input type="text"/>	<input type="text"/>	<input type="text"/>	<input type="text"/>	<input type="text"/>	2	<input type="text"/>
3	avontuur	<input type="text"/>	<input type="text"/>	<input type="text"/>	<input type="text"/>	<input type="text"/>	<input type="text"/>	<input type="text"/>	<input type="text"/>	<input type="text"/>	<input type="text"/>	3	<input type="text"/>
4	vliegtuig	<input type="text"/>	<input type="text"/>	<input type="text"/>	<input type="text"/>	<input type="text"/>	<input type="text"/>	<input type="text"/>	<input type="text"/>	<input type="text"/>	<input type="text"/>	4	<input type="text"/>
5	bijna	<input type="text"/>	<input type="text"/>	<input type="text"/>	<input type="text"/>	<input type="text"/>	<input type="text"/>	<input type="text"/>	<input type="text"/>	<input type="text"/>	<input type="text"/>	5	<input type="text"/>
6	altijd	<input type="text"/>	<input type="text"/>	<input type="text"/>	<input type="text"/>	<input type="text"/>	<input type="text"/>	<input type="text"/>	<input type="text"/>	<input type="text"/>	<input type="text"/>	6	<input type="text"/>
7	wakker	<input type="text"/>	<input type="text"/>	<input type="text"/>	<input type="text"/>	<input type="text"/>	<input type="text"/>	<input type="text"/>	<input type="text"/>	<input type="text"/>	<input type="text"/>	7	<input type="text"/>



Match the words with their descriptions.

- | | | | | |
|---|---------|----------------------------|----------------------------|---|
| 1 | actor | <input type="checkbox"/> A | <input type="checkbox"/> O | without other people |
| 2 | advice | <input type="checkbox"/> | <input type="checkbox"/> H | a group of people who are armed and trained to fight |
| 3 | alone | <input type="checkbox"/> | <input type="checkbox"/> E | a pill that reduces pain, swelling and fever |
| 4 | anchor | <input type="checkbox"/> | <input type="checkbox"/> A | someone whose job is acting in plays or films |
| 5 | army | <input type="checkbox"/> | <input type="checkbox"/> R | the sister of someone's father or mother |
| 6 | aspirin | <input type="checkbox"/> | <input type="checkbox"/> N | when someone tells you what you can do |
| 7 | aunt | <input type="checkbox"/> | <input type="checkbox"/> T | a heavy metal object that is dropped from a boat into the water |

Use the words in the box to complete the text.

body, chance, you, kids, when, sleep

- Sleep is more important than _____ may think.
- Just like eating, _____ is necessary for survival.
- It's like giving your _____ a mini-vacation.
- Most _____ between 5 and 12 get about 9.5 hours a night.
- Sleep also gives your brain a _____ to sort things out.
- But no one is exactly sure what happens _____ you're sleeping.



I am

Find the right translation and connect the dots.

- | | | | | | | |
|---|-------------|---|----------|---|---|-------------|
| 1 | ik ben | ↔ | I am | ● | ● | hij is |
| 2 | jij bent | ↔ | you are | ● | ● | jullie zijn |
| 3 | hij is | ↔ | he is | ● | ● | jij bent |
| 4 | zij is | ↔ | she is | ● | ● | zij zijn |
| 5 | het is | ↔ | it is | ● | ● | zij is |
| 6 | wij zijn | ↔ | we are | ● | ● | ik ben |
| 7 | jullie zijn | ↔ | you are | ● | ● | u bent |
| 8 | zij zijn | ↔ | they are | ● | ● | wij zijn |
| 9 | u bent | ↔ | you are | ● | ● | het is |

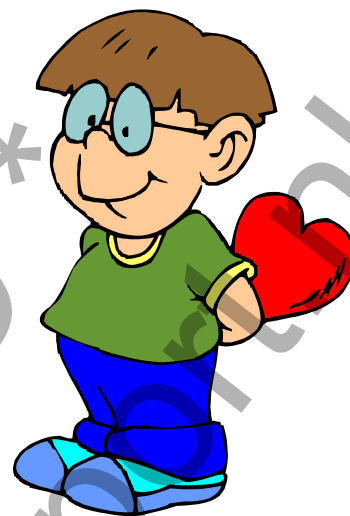

Complete the sentences with am, are, is.

- He _____ in love.
- You _____ in London.
- We _____ at school.
- It _____ not a problem.
- I _____ twelve years old.
- She _____ on a holiday.

Use the green words to fill in the puzzle.

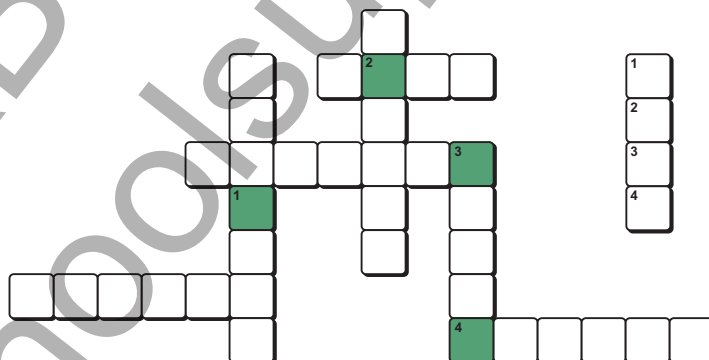

Cross out the wrong word.

- We is / are eating pizza.
- He is / are in the bathroom.
- They is / are always on time.
- It is / are exactly eight o'clock.
- She is / are my sister.
- You is / are a bit late.

Write down every second letter.

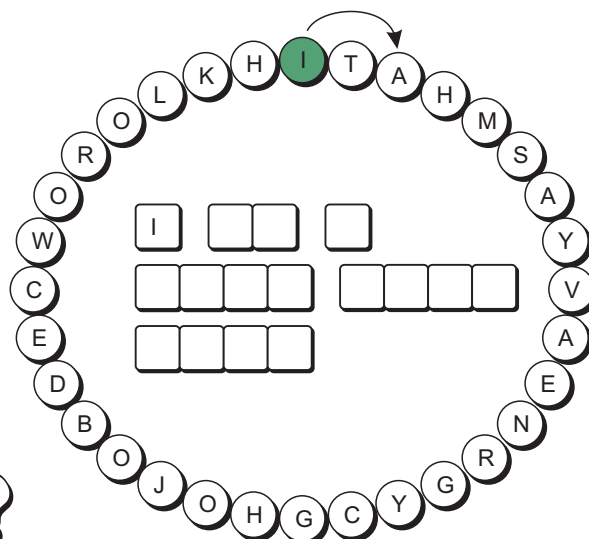

ARE YOU ALL RIGHT?

Voor een zelfstandig naamwoord schrijf je a of an.

- a banana, a girl
- an apple, an egg

Je gebruikt a als je een medeklinker (zoals een b) hoort.

Je gebruikt an als je een klinker (zoals een a) hoort.

Let dus goed op de beginklank van het woord.



Exercise 1

Cross out the wrong answer.

- 1 I am reading a/an book.
- 2 Emma eats a/an apple every day.
- 3 There is a/an owl in the tree.
- 4 Take a/an umbrella with you. It's raining.
- 5 Tom has a/an uncle in Canada.
- 6 He wants to become a/an actor.
- 7 We visited a/an old castle.
- 8 She works as a/an pilot for Delta Airlines.

Exercise 2

Draw a line to all words with 'an'.

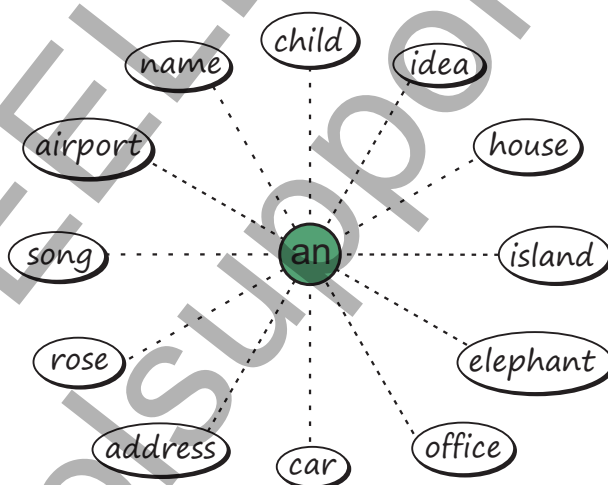

Exercise 3

Tick the right box.

- | | |
|--|---|
| 1 <input type="checkbox"/> a English film | <input type="checkbox"/> an English film |
| 2 <input type="checkbox"/> a thief | <input type="checkbox"/> an thief |
| 3 <input type="checkbox"/> a small opening | <input type="checkbox"/> an small opening |
| 4 <input type="checkbox"/> a easy question | <input type="checkbox"/> an easy question |
| 5 <input type="checkbox"/> a angry man | <input type="checkbox"/> an angry man |
| 6 <input type="checkbox"/> a nice day | <input type="checkbox"/> an nice day |
| 7 <input type="checkbox"/> a airport | <input type="checkbox"/> an airport |
| 8 <input type="checkbox"/> a happy meal | <input type="checkbox"/> an happy meal |

Exercise 4

Cross out the wrong word.

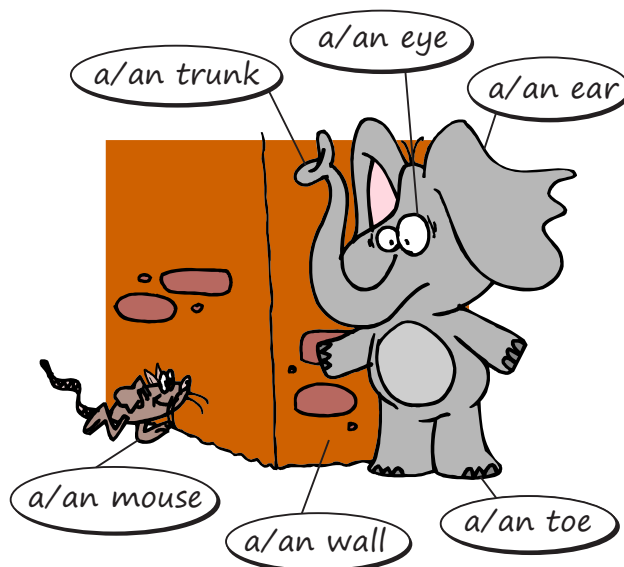



A tennis, B basketball, C football, D volleyball

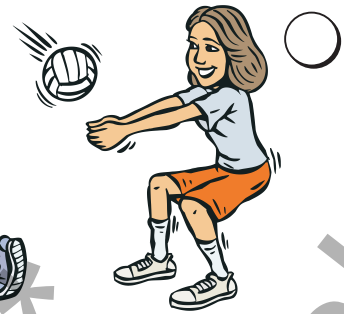
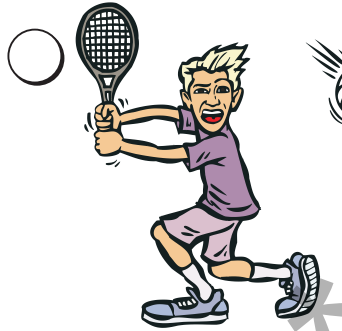

Match the words with their descriptions.

- | | | |
|-------------|----------------------------|---|
| 1 stadium | <input type="checkbox"/> R | C someone who has won the first prize |
| 2 medal | <input type="checkbox"/> | D you need this to measure the exact time |
| 3 champion | <input type="checkbox"/> | E a prize in a sporting event |
| 4 supporter | <input type="checkbox"/> | R the sound of people clapping their hands |
| 5 applause | <input type="checkbox"/> | O a fan of a sports team |
| 6 stopwatch | <input type="checkbox"/> | R a large sports ground with seats all round it |

Underline the words that rhyme.

I'm into sports
so I jump and glide
run and slide
I skate and I ski
and (to be honest)
nobody does it better
than ME!

How many sports are there in the spiral?

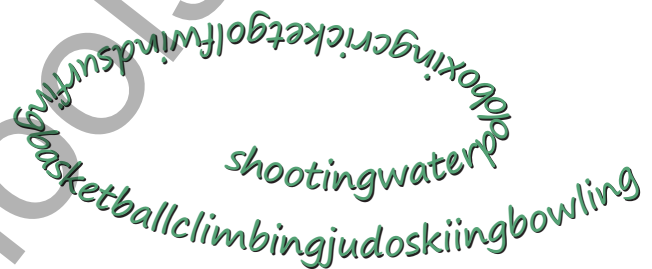

- 9 10 11

Write the words in alphabetical order.

players, winning, goals, training, finish, score

1	<input type="text"/>	<input type="text"/>	<input type="text"/>	<input type="text"/>	<input type="text"/>	<input type="text"/>	<input type="text"/>	<input type="text"/>	<input type="text"/>	1
2	<input type="text"/>	<input type="text"/>	<input type="text"/>	<input type="text"/>	<input type="text"/>	<input type="text"/>	<input type="text"/>	<input type="text"/>	<input type="text"/>	2
3	<input type="text"/>	<input type="text"/>	<input type="text"/>	<input type="text"/>	<input type="text"/>	<input type="text"/>	<input type="text"/>	<input type="text"/>	<input type="text"/>	3
4	<input type="text"/>	<input type="text"/>	<input type="text"/>	<input type="text"/>	<input type="text"/>	<input type="text"/>	<input type="text"/>	<input type="text"/>	<input type="text"/>	4
5	<input type="text"/>	<input type="text"/>	<input type="text"/>	<input type="text"/>	<input type="text"/>	<input type="text"/>	<input type="text"/>	<input type="text"/>	<input type="text"/>	5
6	<input type="text"/>	<input type="text"/>	<input type="text"/>	<input type="text"/>	<input type="text"/>	<input type="text"/>	<input type="text"/>	<input type="text"/>	<input type="text"/>	6

Colour this gliding surfer.





Practise this dialogue with a classmate.

Hi, I'm Lisa. What's your name?

Hi Tom. How old are you?

I'm ten, but my birthday is next month.

I am looking for someone to play with.

Great. Let's play football then.

Alright. Let's go. We can play it in the park.

I'll show you where it is. Come on!

Hello Lisa, I'm Tom.

I'm eleven years old.

What are you doing here?

Then I'm the one you are looking for!

I like basketball better.

Where's that?

Fill in your own names and sports. And speak.

- ★ Hi, I'm _____. What's your name?
- Hello _____. I'm _____.
- ★ Hi, _____. How old are you?
- I'm _____, but my birthday is _____.
- ★ What are you doing here?
- I'm looking for someone to play with.
- ★ Then I'm the one you are looking for.
- Great! Let's play _____ then.
- ★ I like _____ better.
- Alright. Let's go. We can play it in the park.
- ★ Where's that?
- I'll show you where it is. Come on!

Talk about sports.

- Do you like to play sports?
- Why do you like it (or not)?
- Which sports do you like best?
- Are your friends sporty?



Write these seven words in alphabetical order.

angry, August, after, also, above, attack, again

1	boven	<input type="text"/> <input type="text"/> <input type="text"/> <input type="text"/> <input type="text"/>	<input type="text"/>
2	na	<input type="text"/> <input type="text"/> <input type="text"/> <input type="text"/> <input type="text"/>	<input type="text"/>
3	opnieuw	<input type="text"/> <input type="text"/> <input type="text"/> <input type="text"/> <input type="text"/> <input type="text"/>	<input type="text"/>
4	ook	<input type="text"/> <input type="text"/> <input type="text"/> <input type="text"/>	<input type="text"/>
5	boos	<input type="text"/> <input type="text"/> <input type="text"/> <input type="text"/>	<input type="text"/>
6	aanval	<input type="text"/> <input type="text"/> <input type="text"/> <input type="text"/> <input type="text"/> <input type="text"/>	<input type="text"/>
7	augustus	<input type="text"/> <input type="text"/> <input type="text"/> <input type="text"/> <input type="text"/> <input type="text"/> <input type="text"/>	<input type="text"/>

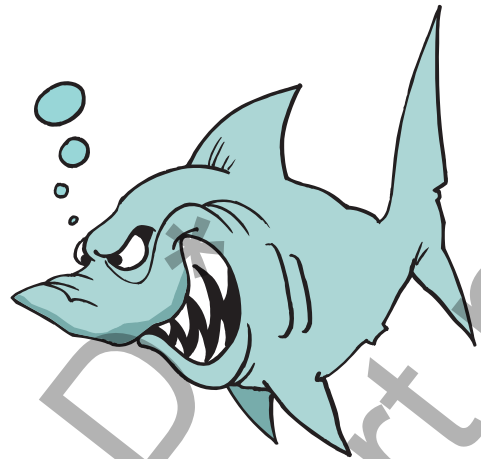

Match the words. Write down the green letters.

7 active 4 against alle actrice
 leeftijd 1 applause tegen
 5 answer actief 8 actress
 3 all 6 airport antwoord
 applaus 2 age vliegveld

1 A 2 3 4 5 6 7 8

Find the right combination.

1	angry	<input type="radio"/>	<input type="radio"/>	question
2	answer	<input type="radio"/>	<input type="radio"/>	eleven
3	all	<input type="radio"/>	<input type="radio"/>	happy
4	age	<input type="radio"/>	<input type="radio"/>	clapping
5	August	<input type="radio"/>	<input type="radio"/>	flying
6	airport	<input type="radio"/>	<input type="radio"/>	film
7	applause	<input type="radio"/>	<input type="radio"/>	month
8	actress	<input type="radio"/>	<input type="radio"/>	everyone

Use the words in the box to complete the text.

birds, flight, first, pilot, airport, military

- The _____ aircraft landed at Schiphol in 1916.
- Schiphol was a _____ airport until May 1920.
- On that day the first KLM _____ took place.
- The _____ flew from London to Amsterdam.
- Then Schiphol became a civilian _____ too.
- Schiphol now has 15 'Bird Controllers' to chase _____.

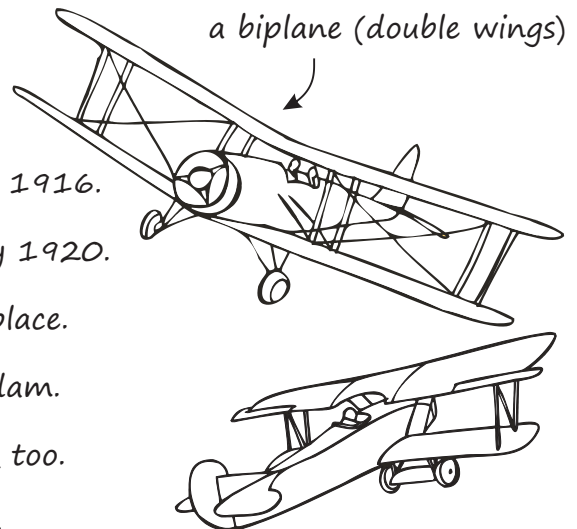

Find the right translation and connect the dots.

- | | | | | | | |
|---|---------------|---|----------|---|---|---------------|
| 1 | ik vraag | ↔ | I ask | ● | ● | zij vragen |
| 2 | jij vraagt | ↔ | you ask | ● | ● | hij vraagt |
| 3 | hij vraagt | ↔ | he asks | ● | ● | wij vragen |
| 4 | zij vraagt | ↔ | she asks | ● | ● | u vraagt |
| 5 | het vraagt | ↔ | it asks | ● | ● | jij vraagt |
| 6 | wij vragen | ↔ | we ask | ● | ● | ik vraag |
| 7 | jullie vragen | ↔ | you ask | ● | ● | zij vraagt |
| 8 | zij vragen | ↔ | they ask | ● | ● | jullie vragen |
| 9 | u vraagt | ↔ | you ask | ● | ● | het vraagt |

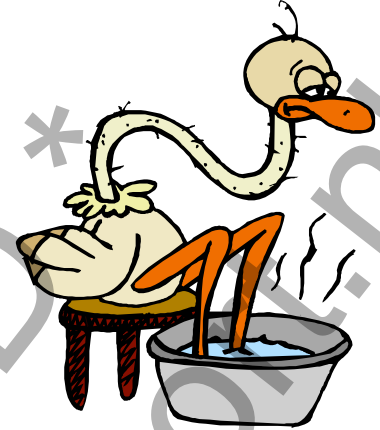

Complete the sentences with ask or asks.

- You _____ the right questions.
- He _____ for an aspirin.
- We _____ for your attention.
- You _____ the impossible.
- She _____ for a short break.
- They _____ for you to be silent.

Use the green words to fill in the puzzle.

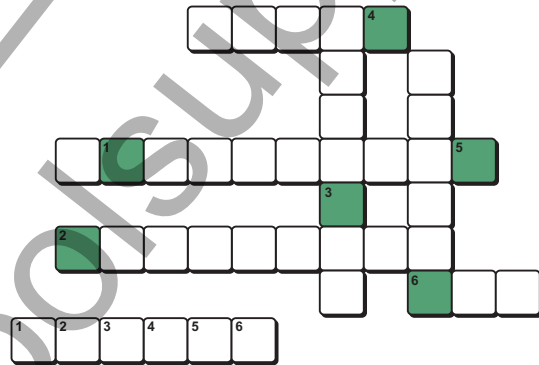

Cross out the wrong word.

- Tom ask / asks if you want to play football.
- They ask / asks how long we will stay here.
- She ask / asks what you want to drink.
- My parents ask / asks what time it is.
- The detective ask / asks clever questions.
- Emily ask / asks if you want to go to the beach.

Colour the lines and follow them all the way.

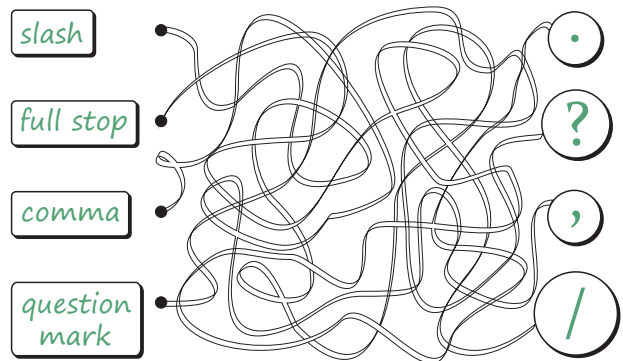

WOULD YOU LIKE TO ASK SOMETHING?

1 Write two words for each picture.

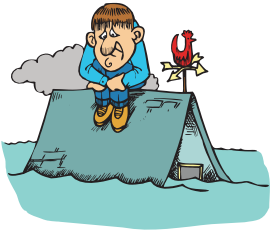

2 Write down eight words that start with the letter **M**

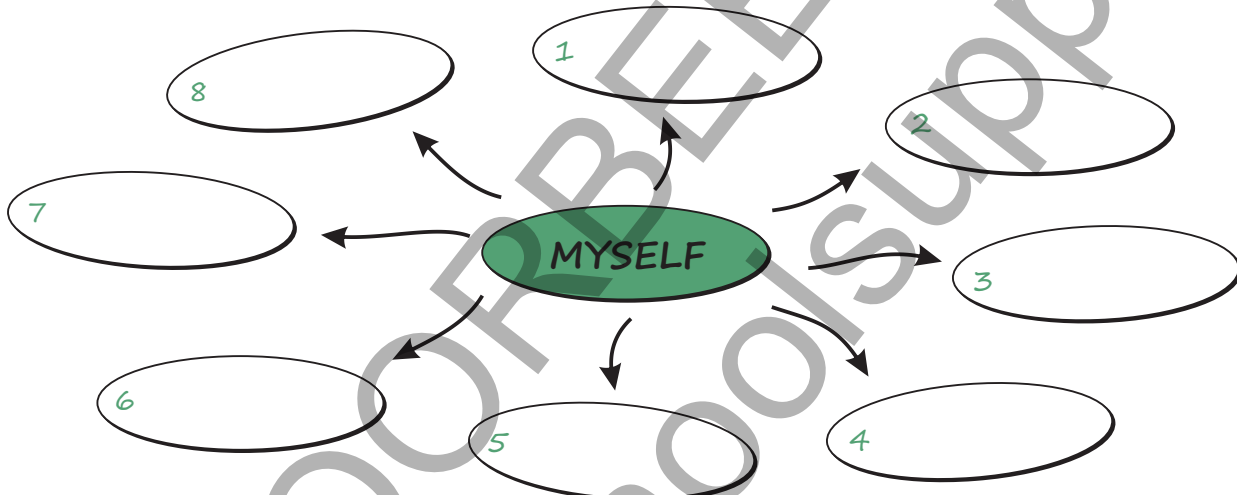

3 Write about yourself and tick the right boxes.

- 1 What is the name of your hometown?
- 2 Mark it on the map.
- 3 When is your birthday?
- 4 Which season do you like best?
 summer autumn winter spring
- 5 What is your favourite food?
- 6 What is your favourite colour?
- 7 Which animal do you like best?





1 Match the words with their descriptions. (6 points)

- | | | |
|------------|--------------------------|--|
| 1 zebra | <input type="checkbox"/> | A the sister of someone's father or mother |
| 2 army | <input type="checkbox"/> | B a small brown animal with sharp spikes on its back |
| 3 stadium | <input type="checkbox"/> | C a group of people who are armed and trained to fight |
| 4 hedgehog | <input type="checkbox"/> | D someone who has won the first prize |
| 5 champion | <input type="checkbox"/> | E an African wild animal with black and white stripes |
| 6 aunt | <input type="checkbox"/> | F a large sports ground with seats all round it |

2 Tick the box if the combination is right. (8 points)

- | | | | |
|---------------|--------------------------|--------------|--------------------------|
| 1 a door | <input type="checkbox"/> | 5 an thief | <input type="checkbox"/> |
| 2 an orange | <input type="checkbox"/> | 6 a question | <input type="checkbox"/> |
| 3 an machine | <input type="checkbox"/> | 7 a book | <input type="checkbox"/> |
| 4 an umbrella | <input type="checkbox"/> | 8 a island | <input type="checkbox"/> |

<input checked="" type="checkbox"/>	exercise 1	<input type="checkbox"/>	points
<input checked="" type="checkbox"/>	exercise 2	<input type="checkbox"/>	points
<input checked="" type="checkbox"/>	exercise 3	<input type="checkbox"/>	points
<input checked="" type="checkbox"/>	Total	<input type="checkbox"/>	points

3 Translate the words and phrases. (10 points)

- | | | | | | |
|------------|---|-------|---------------|---|-------|
| 1 always | → | _____ | 6 wij zijn | → | _____ |
| 2 angry | → | _____ | 7 hij vraagt | → | _____ |
| 3 accident | → | _____ | 8 ik ben | → | _____ |
| 4 after | → | _____ | 9 u bent | → | _____ |
| 5 awake | → | _____ | 10 zij vragen | → | _____ |

What comes next? Check it out.

Translate the words and phrases. (10 points)

- | | | | | | |
|------------|---|-------|-----------------|---|-------|
| 1 history | → | _____ | 6 zij doet | → | _____ |
| 2 beach | → | _____ | 7 wij kopen | → | _____ |
| 3 accident | → | _____ | 8 jouw tas | → | _____ |
| 4 thaw | → | _____ | 9 onze tijd | → | _____ |
| 5 forecast | → | _____ | 10 zijn kaartje | → | _____ |

14-16 points: okay
17-20 points: good
21-24 points: excellent

5-6 points: okay
7-8 points: good
9-10 points: excellent



A geography, B reading, C science, D doing sums

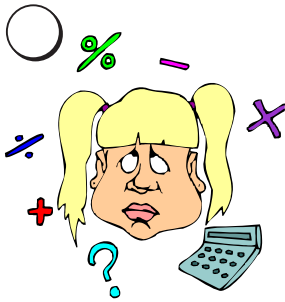

Match the words with their descriptions.

- | | | |
|------------|----------------------------|--|
| 1 biology | <input type="checkbox"/> F | D the study of events that happened in the past |
| 2 calendar | <input type="checkbox"/> | E someone who works at a school |
| 3 English | <input type="checkbox"/> | R a table that shows the days, weeks, and months of a year |
| 4 teacher | <input type="checkbox"/> | N all sort of questions to find out what you know |
| 5 test | <input type="checkbox"/> | F the study of everything that lives |
| 6 history | <input type="checkbox"/> | I the language spoken by people in the United Kingdom |

Underline the words that rhyme.

school today
 doing sums and English too
 that's how I start
 what about you?
 reading, writing
 texts and tests
 I just wonder if you know
 when they finally let you go?

How many words are there in the spiral?

- fourteen fifteen sixteen

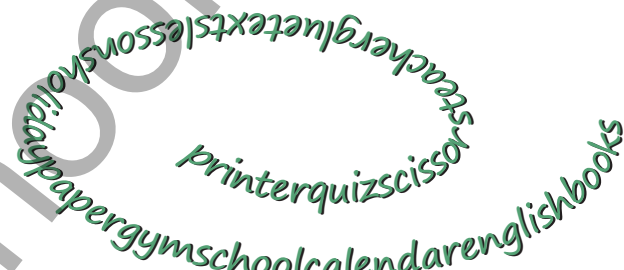

Write the words in alphabetical order.

project, glue, scissors, question, answer, ruler

1	<input type="text"/>	<input type="text"/>	<input type="text"/>	<input type="text"/>	<input type="text"/>	<input type="text"/>	<input type="text"/>	1
2	<input type="text"/>	<input type="text"/>	<input type="text"/>	<input type="text"/>	<input type="text"/>	<input type="text"/>	<input type="text"/>	2
3	<input type="text"/>	<input type="text"/>	<input type="text"/>	<input type="text"/>	<input type="text"/>	<input type="text"/>	<input type="text"/>	3
4	<input type="text"/>	<input type="text"/>	<input type="text"/>	<input type="text"/>	<input type="text"/>	<input type="text"/>	<input type="text"/>	4
5	<input type="text"/>	<input type="text"/>	<input type="text"/>	<input type="text"/>	<input type="text"/>	<input type="text"/>	<input type="text"/>	5
6	<input type="text"/>	<input type="text"/>	<input type="text"/>	<input type="text"/>	<input type="text"/>	<input type="text"/>	<input type="text"/>	6

What are you good at?

- spelling music sports sums English





Practise this dialogue with a classmate.

Jessica, what are you doing?

I'm trying to do my homework.

What are you talking about? Homework?

Yes dad. History. The things of the past.

I can't hear you. There is too much noise.

Noise? That's my favourite music!

I can't hear myself anymore. Turn it down.

But it helps me to concentrate.

Well, it helps me to get angry.

Alright. Is this better?

It is. I can even hear you now! Keep it low.

I will. But it's harder to study now.

That's exactly how it was in the past!

Don't forget that this is the present dad!

Ask a classmate the following questions.

- 1 What is your best subject?
- 2 Which schoolday do you like best and why?
- 3 How many children are there in your group?
- 4 How much time do you spend on English?
- 5 How often do you get homework?
- 6 What do you like best about school?
- 7 Is the playground big enough?

Useful words and phrases.

- history geschiedenis
- angry boos
- the present deze tijd, nu
- subject schoolvak

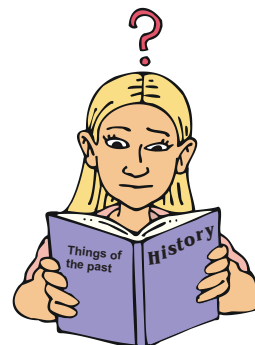

Write these seven words in alphabetical order.

battery, beaver, banana, beach, bamboo, beard, basket

1	bamboe	<input type="text"/>	3	<input type="text"/>
2	banaan	<input type="text"/>	4	<input type="text"/>
3	mand	<input type="text"/>	6	<input type="text"/>
4	batterij	<input type="text"/>	7	<input type="text"/>
5	strand	<input type="text"/>	1	<input type="text"/>
6	baard	<input type="text"/>	5	<input type="text"/>
7	bever	<input type="text"/>	2	<input type="text"/>



Choose the right word for each sentence.

- | | | | | |
|---|--|-----------------------|-----------------------|----------|
| 1 | His favourite school subject is _____. | <input type="radio"/> | <input type="radio"/> | bread |
| 2 | My mother bought a _____ of orange juice. | <input type="radio"/> | <input type="radio"/> | birthday |
| 3 | We had a quick meal of _____ and soup. | <input type="radio"/> | <input type="radio"/> | bottle |
| 4 | Let's go to the _____. I want to swim. | <input type="radio"/> | <input type="radio"/> | between |
| 5 | The office is closed _____ 12.30 and 1.30. | <input type="radio"/> | <input type="radio"/> | biology |
| 6 | They're building a new _____ across the river. | <input type="radio"/> | <input type="radio"/> | beach |
| 7 | Are you going to his _____ party next week? | <input type="radio"/> | <input type="radio"/> | bridge |

Use the words in the box to complete the text.

dreams, boss, brain, sponge, way, controls

- How do you remember the _____ to your friend's house?
- Where do _____ come from?
- Your _____ is in charge of these things and a lot more.
- In fact, your brain is the _____ of your body.
- It _____ just about everything you do.
- Not bad for something that looks like a gray, wrinkly _____.

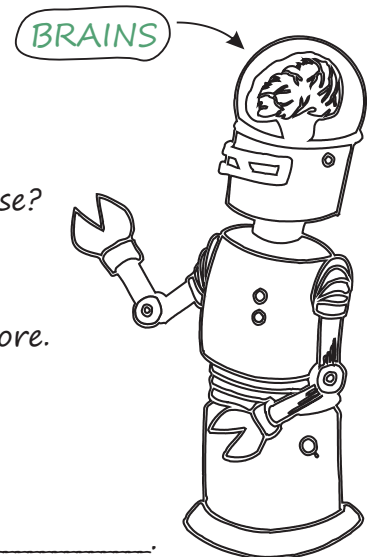

Find the right translation and connect the dots.

- | | | | | | | |
|---|--------------|----|----------|---|---|--------------|
| 1 | ik koop | ←→ | I buy | ● | ● | zij koopt |
| 2 | jij koopt | ←→ | you buy | ● | ● | ik koop |
| 3 | hij koopt | ←→ | he buys | ● | ● | het koopt |
| 4 | zij koopt | ←→ | she buys | ● | ● | jij koopt |
| 5 | het koopt | ←→ | it buys | ● | ● | u koopt |
| 6 | wij kopen | ←→ | we buy | ● | ● | jullie kopen |
| 7 | jullie kopen | ←→ | you buy | ● | ● | zij kopen |
| 8 | zij kopen | ←→ | they buy | ● | ● | hij koopt |
| 9 | u koopt | ←→ | you buy | ● | ● | wij kopen |



Complete the sentences with buy or buys.

- He _____ her a present.
- You _____ whatever you like.
- They _____ and sell furniture.
- I _____ most of my shoes myself.
- She _____ all her books online.
- They _____ their products in China.

Use the green words to fill in the puzzle.

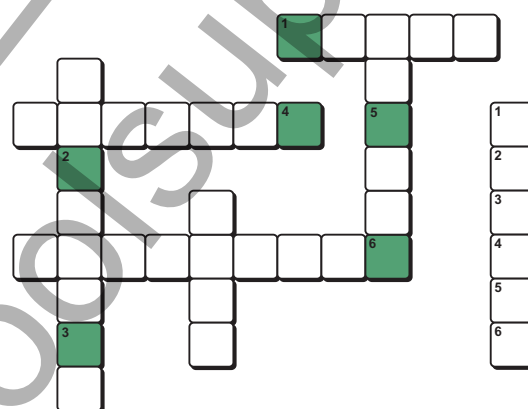

Cross out the wrong word.

- Rose buy / buys everyone gifts.
- Our company buy / buys old mobile phones.
- We buy / buys our food at the supermarket.
- William buy / buys his girlfriend a ring.
- My dad buy / buys us popcorn and lemonade.
- Many people buy / buys a used car.

1 head light, 2 roof, 3 bumper, 4 grill

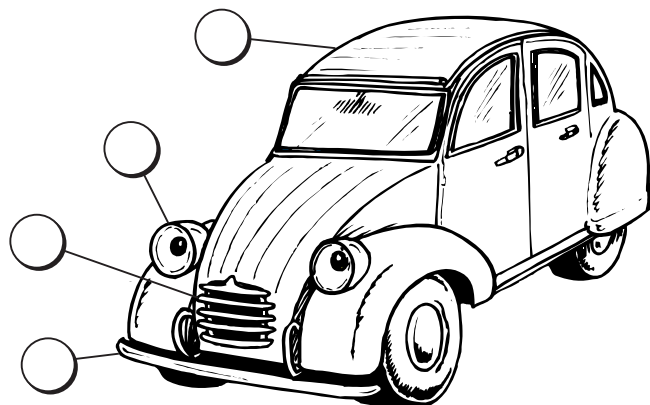

THIS CAR IS CALLED A CITROËN 2CV.

Je gebruikt bezittelijke voornaamwoorden om aan te geven van wie iets is.

- mijn ouders my parents
- jouw potlood your pencil
- onze buren our neighbours

Voor jouw, uw en jullie gebruik je hetzelfde woord: **your**

● mijn	→	my
● jouw/uw	→	your
● zijn	→	his
● haar	→	her
● ons/onze	→	our
● jullie/uw	→	your
● hun	→	their

Exercise 2

Cross out the wrong answer.

- onze tijd ●● your / our time
- zijn huiswerk ●● his / her homework
- jouw vrienden ●● your / our friends
- mijn kaartje ●● his / my ticket
- hun succes ●● our / their success

Exercise 4

Fill in: your, his, my, her, their

- She has a new ring. It's ring.
- They have a dog. It's dog.
- I have some money. It's money.
- You have a sister. It's sister
- He has a bottle. It's bottle.

1	2	3	4	5	6
---	---	---	---	---	---

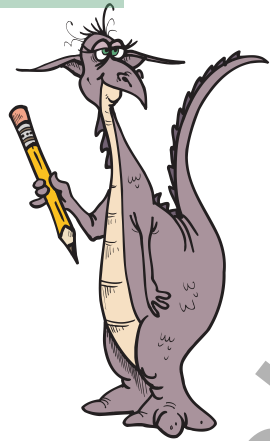

Exercise 1

Vul het juiste woord in.

- Is this (jouw) _____ bicycle?
- (Mijn) _____ parents are French.
- (Hun) _____ team won the boat race.
- That was (zijn) _____ idea.
- (Onze) _____ school starts at 8.30am.

Exercise 3

Connect the right dots with a line.

- | | | |
|-----------------|---|-----------------|
| 1 your bag | ● | ● haar antwoord |
| 2 her answer | ● | ● hun vakantie |
| 3 our clothes | ● | ● zijn verhalen |
| 4 his stories | ● | ● jouw tas |
| 5 their holiday | ● | ● onze kleren |

Exercise 5

A tail, B teeth, C lance, D leg, E shield, F hoof

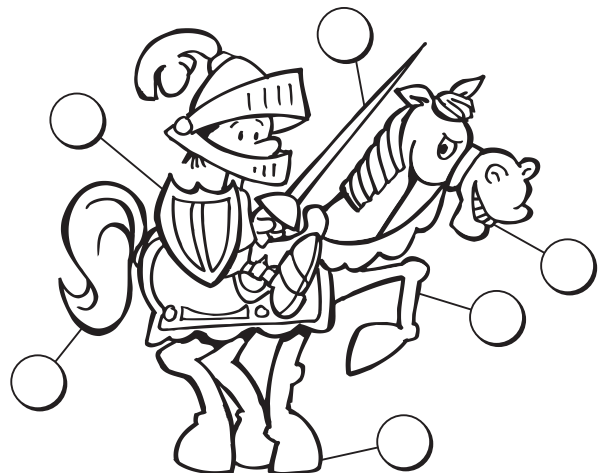



A melting, B heatwave, C flooding, D windy

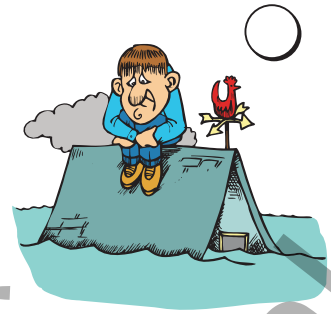
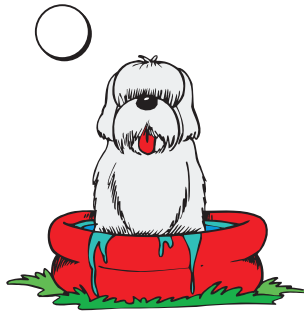
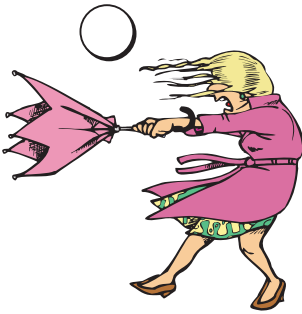

Match the words with their descriptions.

- | | | |
|-------------|---------------------------------------|--|
| 1 shower | <input checked="" type="checkbox"/> S | W an instrument that measures air pressure |
| 2 forecast | <input type="checkbox"/> | D a period of warmer weather when snow and ice melt |
| 3 parasol | <input type="checkbox"/> | H a statement saying what the weather will be like the next days |
| 4 thaw | <input type="checkbox"/> | S a short period of rain |
| 5 thunder | <input type="checkbox"/> | A an object like an umbrella that provides shade from the sun |
| 6 barometer | <input type="checkbox"/> | O the loud noise that you hear after a flash of lightning |

Underline the words that rhyme.

windy storms
coming from the west
that's the weather
I like best
showers of rains
and snowflakes in the sky
that's when I
start feeling high!

Fill in today's weather report.

<input checked="" type="checkbox"/> temperature	_____ °C	<input type="checkbox"/> cold	<input type="checkbox"/> normal	<input type="checkbox"/> hot
<input checked="" type="checkbox"/> wind	<input type="checkbox"/> yes <input type="checkbox"/> no	<input type="checkbox"/> calm	<input type="checkbox"/> gentle	<input type="checkbox"/> strong
<input checked="" type="checkbox"/> air pressure	_____ mb	<input type="checkbox"/> low	<input type="checkbox"/> normal	<input type="checkbox"/> high
<input checked="" type="checkbox"/> clouds	<input type="checkbox"/> yes <input type="checkbox"/> no	<input type="checkbox"/> a few	<input type="checkbox"/> normal	<input type="checkbox"/> many
<input checked="" type="checkbox"/> sunshine	<input type="checkbox"/> yes <input type="checkbox"/> no	<input type="checkbox"/> a bit	<input type="checkbox"/> normal	<input type="checkbox"/> much
<input checked="" type="checkbox"/> rain/snow/hail	<input type="checkbox"/> yes <input type="checkbox"/> no	<input type="checkbox"/> a bit	<input type="checkbox"/> normal	<input type="checkbox"/> much

Write the words in alphabetical order.

south, calm, storm, climate, tornado, spells

1	<input type="text"/>	<input type="text"/>	<input checked="" type="checkbox"/>	<input type="text"/>	1	<input type="text"/>		
2	<input checked="" type="checkbox"/>	<input type="text"/>	<input type="text"/>	<input type="text"/>	<input type="text"/>	2	<input type="text"/>	
3	<input type="text"/>	<input type="text"/>	<input checked="" type="checkbox"/>	<input type="text"/>	<input type="text"/>	3	<input type="text"/>	
4	<input type="text"/>	<input type="text"/>	<input type="text"/>	<input checked="" type="checkbox"/>	<input type="text"/>	4	<input type="text"/>	
5	<input type="text"/>	<input type="text"/>	<input checked="" type="checkbox"/>	<input type="text"/>	<input type="text"/>	5	<input type="text"/>	
6	<input type="text"/>	<input type="text"/>	<input type="text"/>	<input type="text"/>	<input checked="" type="checkbox"/>	<input type="text"/>	6	<input type="text"/>

Going down the waterslide!





Practise this dialogue with a classmate.

The weather forecast with Jim Kent.

Quiet everyone! I really want to hear this.

Cloudy and rainy spells all day.

Yes, I can see and feel that for myself.

The weekend will be sunny and warm.

Now you're talking Jim! That's good news.

But next week, it will start raining again.

You know that's not what I want to hear.

So raincoats on and umbrellas up.

Stop it man. Just give me some sunshine.

Don't forget to enjoy the weather today.

It's raining. What kind of advice is that?

Thanks for listening to our news report.

I wish you listened to me for once!

Ask a classmate the following questions.

- 1 Would you like to be a weather reporter?
- 2 Do you ever listen to the weather forecast?
- 3 What's the weather like today?
- 4 Which of the four seasons do you like best?
- 5 Are you afraid of thunder and lightning?
- 6 Would you like to live in a sunny country?
- 7 What's the temperature in your classroom now?
- 8 What will the weather be like tomorrow?

Useful words and phrases.

- weather forecast weersverwachting
- cloudy bewolkt
- spells periodes
- umbrella paraplu
- season seizoen



Write these seven words in alphabetical order.

carpet, canoe, cage, chain, cartoon, chase, cable

1	kabel	<input type="text"/>	<input type="text"/>	<input type="text"/>	<input type="text"/>	<input type="text"/>	<input type="text"/>	1
2	kooi	<input type="text"/>	<input type="text"/>	<input type="text"/>	<input type="text"/>	<input type="text"/>	<input type="text"/>	2
3	kano	<input type="text"/>	<input type="text"/>	<input type="text"/>	<input type="text"/>	<input type="text"/>	<input type="text"/>	3
4	tapijt	<input type="text"/>	<input type="text"/>	<input type="text"/>	<input type="text"/>	<input type="text"/>	<input type="text"/>	4
5	tekenfilm	<input type="text"/>	<input type="text"/>	<input type="text"/>	<input type="text"/>	<input type="text"/>	<input type="text"/>	5
6	ketting	<input type="text"/>	<input type="text"/>	<input type="text"/>	<input type="text"/>	<input type="text"/>	<input type="text"/>	6
7	jacht	<input type="text"/>	<input type="text"/>	<input type="text"/>	<input type="text"/>	<input type="text"/>	<input type="text"/>	7



Write the green words in the correct sentence.

- We went down the river in a _____.
- She locked her bicycle with a _____.
- John let the hamster out of the _____.
- There was a blue _____ on the floor.
- The _____ starts at 8 o'clock tonight.
- I plugged the _____ into my computer.
- They were watching a Disney _____.

Find the right translation.

- | | | | | |
|---|-------------|-----------------------|-----------------------|------------|
| 1 | costume | <input type="radio"/> | <input type="radio"/> | kathedraal |
| 2 | chain | <input type="radio"/> | <input type="radio"/> | bloemkool |
| 3 | champion | <input type="radio"/> | <input type="radio"/> | kabel |
| 4 | cathedral | <input type="radio"/> | <input type="radio"/> | ketting |
| 5 | cage | <input type="radio"/> | <input type="radio"/> | kampioen |
| 6 | cable | <input type="radio"/> | <input type="radio"/> | kostuum |
| 7 | cauliflower | <input type="radio"/> | <input type="radio"/> | kooi |

Use the words in the box to complete the text.

four, London, Tunnel, United, Wales, cities

- The UK means the _____ Kingdom.
- It consists of _____ countries.
- England, _____, Scotland and Northern Ireland.
- The capital city of England is _____.
- Other big _____ are Birmingham and Liverpool.
- The Channel _____ opened in 1994.

UNION FLAG

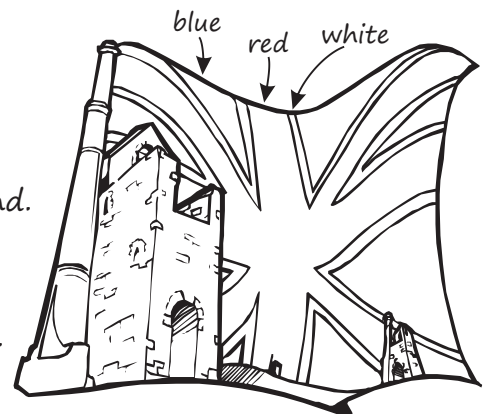

Find the right translation and connect the dots.

- | | | | | | | |
|---|-------------|----|----------|---|---|-------------|
| 1 | ik doe | ←→ | I do | ● | ● | jullie doen |
| 2 | jij doet | ←→ | you do | ● | ● | zij doet |
| 3 | hij doet | ←→ | he does | ● | ● | u doet |
| 4 | zij doet | ←→ | she does | ● | ● | zij doen |
| 5 | het doet | ←→ | it does | ● | ● | hij doet |
| 6 | wij doen | ←→ | we do | ● | ● | het doet |
| 7 | jullie doen | ←→ | you do | ● | ● | jij doet |
| 8 | zij doen | ←→ | they do | ● | ● | ik doe |
| 9 | u doet | ←→ | you do | ● | ● | wij doen |



Complete the sentences with do or does.

- You _____ what is right.
- He _____ the shopping.
- We _____ the dishes.
- They _____ the cooking.
- I _____ a lot of training.
- She _____ what is best.

Use the green words to fill in the puzzle.

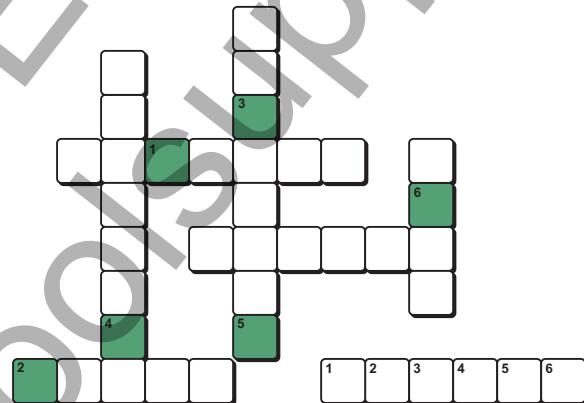

Cross out the wrong word.

- She do / does this for you.
- It do / does not work.
- They do / does what they can.
- We do / does a test every week.
- I do / does it my way.
- You do / does your job really well.

How many sevens do you see in the tree?



WHAT DO YOU DO WHEN SCHOOL IS DONE?



1 Write two words for each picture.



2 Fill in the word web with eight hospital words.

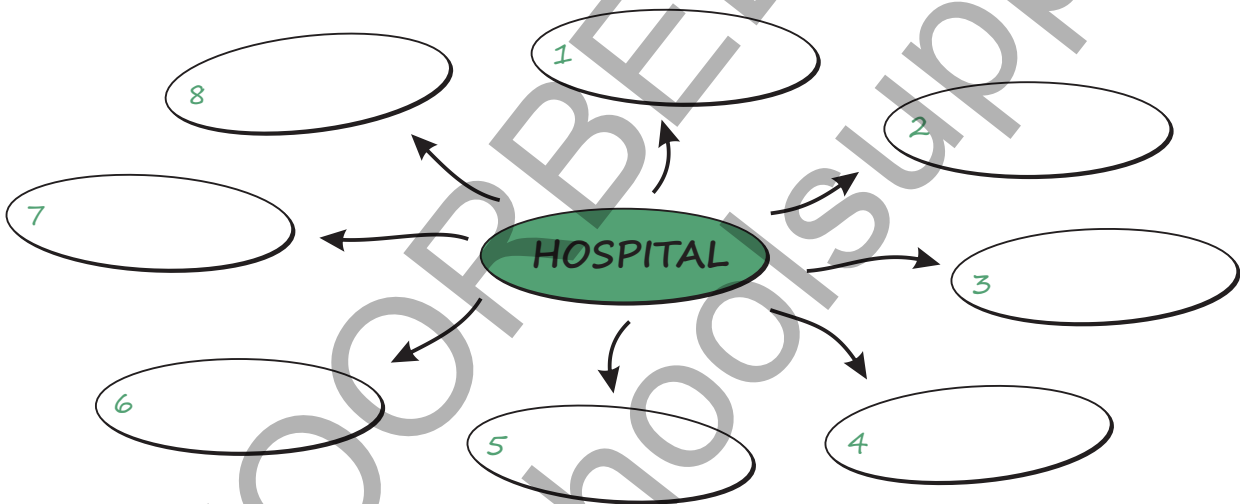

3 Look up these words in a dictionary.

- 1 bandage → _____
- 2 health → _____
- 3 kidney → _____
- 4 surgeon → _____
- 5 treatment → _____
- 6 wheelchair → _____

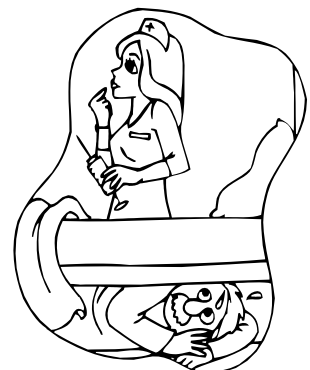

**1 Match the words with their descriptions. (6 points)**

- | | | |
|------------|--------------------------|--|
| 1 test | <input type="checkbox"/> | A a table that shows the days, weeks, and months of a year |
| 2 calendar | <input type="checkbox"/> | B someone who works at a school |
| 3 forecast | <input type="checkbox"/> | C a short period of rain |
| 4 shower | <input type="checkbox"/> | D all sort of questions to find out what you know |
| 5 teacher | <input type="checkbox"/> | E the loud noise that you hear after a flash of lightning |
| 6 thunder | <input type="checkbox"/> | F a statement saying what the weather will be like the next days |

2 Translate the words in English. (4 points)

- 1 jouw hond → _____
- 2 zijn auto → _____
- 3 onze school → _____
- 4 hun moeder → _____

✓ exercise 1	<input type="checkbox"/>	points
✓ exercise 2	<input type="checkbox"/>	points
✓ exercise 3	<input type="checkbox"/>	points
✓ Total	<input type="checkbox"/>	points

3 Translate the words and phrases. (10 points)

- | | |
|------------------|----------------------|
| 1 chain → _____ | 6 u koopt → _____ |
| 2 basket → _____ | 7 hij koopt → _____ |
| 3 cage → _____ | 8 ik koop → _____ |
| 4 beard → _____ | 9 zij kopen → _____ |
| 5 chase → _____ | 10 jij koopt → _____ |

11-13 points: okay
14-16 points: good
17-20 points: excellent

What comes next? Check it out.**Translate the words and phrases. (10 points)**

- | | |
|-------------------|----------------------|
| 1 chicken → _____ | 6 zij zijn → _____ |
| 2 chance → _____ | 7 wij hebben → _____ |
| 3 scarf → _____ | 8 zij gaat → _____ |
| 4 cave → _____ | 9 hij is → _____ |
| 5 glove → _____ | 10 het heeft → _____ |

5-6 points: okay
7-8 points: good
9-10 points: excellent



diploma

This diploma is presented to

GET STARTED
DOWNLOAD COMPLETED #1

Date

Signature

